

**BLÜCHER®**

KITCHEN CHANNELS ON BOARD



K E E P I N G   U P   T H E   F L O W

STAINLESS STEEL DRAINAGE SYSTEMS



## CHANNELS ON BOARD

At BLÜCHER we have more than 40 years of experience with stainless steel drainage systems, and hygienic solutions for the food industry is one of our specialities.

The combination of stainless steel and careful product design gives you many advantages.

### **Hygienic**

Stainless steel has a smooth surface which is easy to clean, and the BLÜCHER® products are designed without cavities and corners inside leaving no space for deposits.

Accessories like removable water traps also contribute to fast and easy cleaning.

### **Stable**

The BLÜCHER® Channel product program is produced largely from 2 mm stainless steel providing the highest levels of stability and durability.

### **Fire resistant**

Stainless steel is a fire resistant material.

### **Easy connection**

BLÜCHER® Channel fits into the BLÜCHER® Drain Marine lower parts which fit into the lightweight drainage pipe-work system BLÜCHER® EuroPipe.

### **Shear resistant**

The high tensile strength of stainless steel makes the system resistant to shear breakage and cracking.

### **Temperature resistant**

Discharge of liquids at temperatures up to 120 °C will not influence the material.

### **100% recyclable**

Stainless steel is 100% recyclable and is with its long life environmentally friendly. BLÜCHER® Channel is made from stainless steel which has a recycled content over 70% scrap.



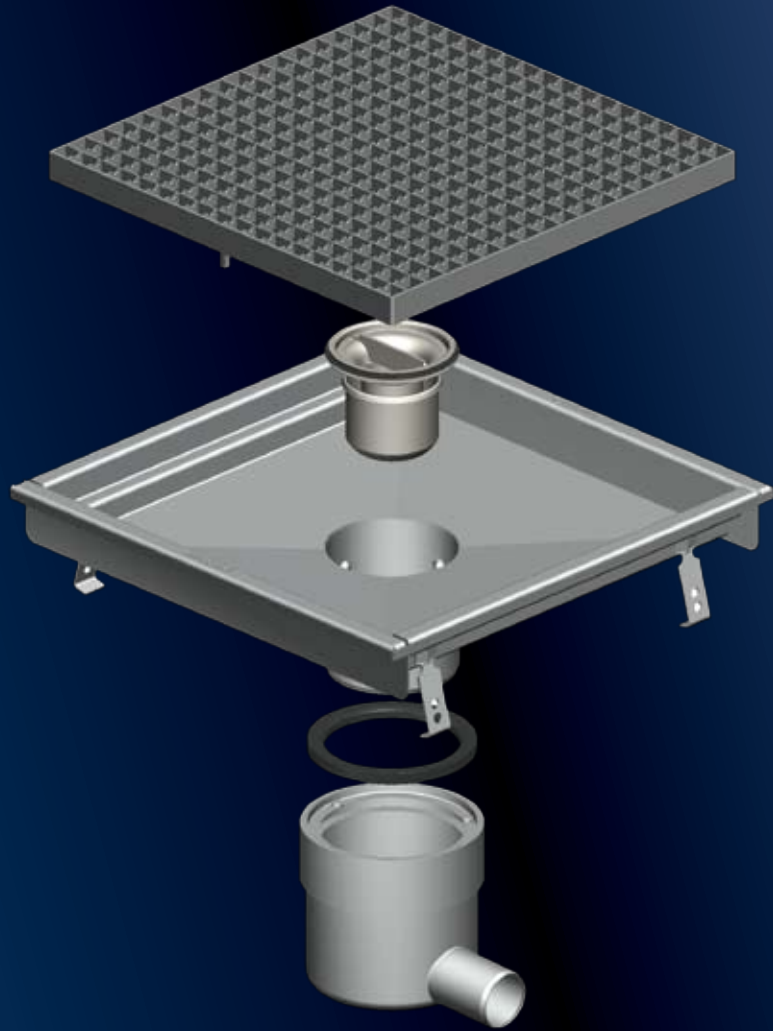

## PRODUCT RANGE

The BLÜCHER® Channel program includes a complete range of channels and kitchen channels for tiled or vinyl floors. On board BLÜCHER recommends the use of AISI 316L stainless steel because using this steel quality, the risk of corrosion, caused by an aggressive environment and salt water, is significantly reduced or eliminated entirely.

### Freedom of choice with standard solutions

All products are combinable with the BLÜCHER® Drain range of floor drains. All accessories like gratings and water traps are also part of the standard program. Among the numerous advantages of the BLÜCHER® Channel range are:

- Removable water trap for easy cleaning
- Perfect surface finish
- Gratings for any load class

Our technical experts are always willing to assist you in selecting the right channel for your requirements, based on water flow, waste products, weight load and floor covering.

### Customised solutions

We are specialised in customised solutions. Please contact us, and we will make a solution fulfilling exactly your requirements. For instance:

- Corners and T-pieces
- Customised lengths and widths
- Customised designs
- Channels for other floor types
- Other gratings

### Installation

Standard and special solutions are based on the same modular system ensuring simple and quick installation. The channel is connected to one or more welded deck penetrations by means of push-fit joints. Following this, the drainage solution is completed with water trap, filter bucket and grating.



## Selected kitchen channels

### Kitchen channel type 660 for tiled floors

Type No.	Description	F	F1	I	I1	D	H	H5
660FH004-06 S	400x400	437	437	397	397	110	145/195/235	60/110/150
660FH008-06 S	400x800	837	437	797	397	110	145/195/235	60/110/150
660GH005-06 S	500x500	537	537	497	497	110	145/195/235	60/110/150
660GH010-06 S	500x1000	1037	537	997	497	110	145/195/235	60/110/150

Also available in depth H1 110 mm or 150 mm

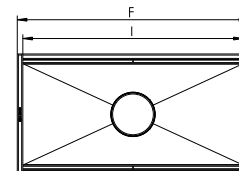
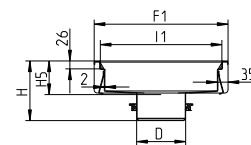

### Kitchen channel type 662 for vinyl floors

Type No.	Description	F	F1	I	I1	D	H	H5
662FH004-06 S	400x400	437	437	397	397	110	145/195/235	60/110/150
662FH008-06 S	400x800	837	437	797	397	110	145/195/235	60/110/150
662GH005-06 S	500x500	537	537	497	497	110	145/195/235	60/110/150
662GH010-06 S	500x1000	1037	537	997	497	110	145/195/235	60/110/150

Also available in depth H1 110 mm or 150 mm

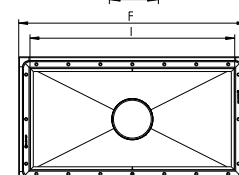
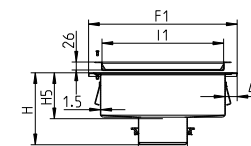

### Selected gratings for kitchen channels

Type No.	Description	LxW	H
696.223.394.395 S	Mesh grating	394x394	25
696.223.494.495 S	Mesh grating	494x494	25

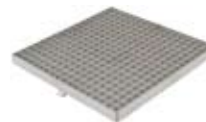

### Accessories for kitchen channels

Type No.	Description	S	D	D2	H5	H	Flow l/sec.
502.052.110 CRS	Water trap	52	108	75	-	93	0.9-1.2
503.000.110	Multi water trap	51	108	75	93	113	0.9-1.3
IG.054CR*	Sealing ring for lower part						

\*Must be used when a lower part is installed

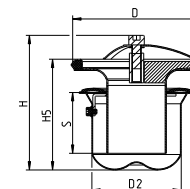
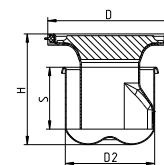

## Selected lower parts with MED certificate

Ⓢ = MED certificate

### Lower part with vertical outlet and welding sleeve

Type No.		X	D1	D2	Kg
470.000.050 S	Ⓢ A0-A60	174	50	150	1.6
470.000.075 S		172	75	150	1.6
470.000.110 S		145	110	150	1.5

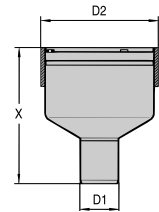

### Lower part with vertical outlet and welding flange

Type No.		D1	D2	D3	X	Kg
470.200.050 S	Ⓢ A0-A60	50	140	200	174	1.3
470.200.075 S		75	140	200	172	1.4
470.200.110 S		110	140	200	145	1.3

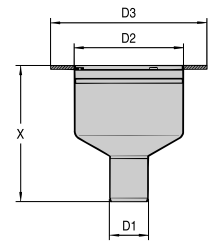

### Lower part with horizontal outlet and welding sleeve

Type No.		D1	D2	X1	X2	B	Kg
475.000.050 S	Ⓢ A0-A60	50	150	117	140	199	1.9
475.000.075 S		75	150	105	140	204	1.8

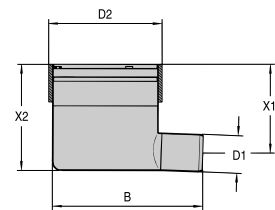

### Lower part with horizontal outlet and welding sleeve, extended height

Type No.		D1	D2	X1	X2	B	Kg
475.100.050 S	Ⓢ A0-A60	50	150	187	164	199	2.1

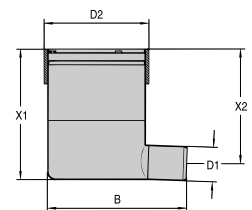

### Lower part with horizontal outlet and welding flange

Type No.		D1	D2	D3	X1	X2	B	Kg
475.200.050 S	Ⓢ A0-A60	50	140	200	106	72	199	1.3
475.200.075 S		75	140	200	106	70	204	1.4

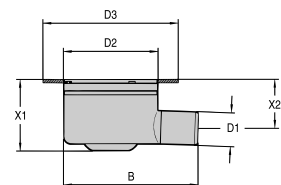

All measurements in mm

# BLÜCHER®

At BLÜCHER® more than 300 employees create an annual turnover of more than 50 million euro.

Through know-how, dedicated service and common sense we develop, produce and market high quality stainless steel drainage solutions for customers within the housing, commercial, industrial and marine sectors all over the world.

Find your local BLÜCHER® specialist at [www.blucher.com](http://www.blucher.com)

**BLÜCHER® EuroPipe**

**BLÜCHER® Channel**

**BLÜCHER® Drain**



KEEPING UP THE FLOW